



## TUBA 111 230V surface

### TUBA 111 230V natynkowy

Category: surface

Power 35W (LED 12,5W)

Light source: ES111, 230V

Lampholder: GU10

Dimming: Phase-Control

Light source not included

Transformer not required.

#### AVAILABLE FINISHES:

MATT GLOSS

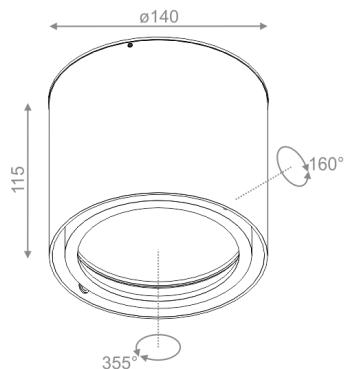

#### AVAILABLE LUMINAIRE LENGTH:

11 cm
23 cm
34 cm

#### AVAILABLE FINISHES:

##### MATT

alu matt	-01	black matt	-02
white matt	-03	anthracite structure	-18
gold structure	-19		

##### GLOSS

black gloss	-22	white gloss	-23
-------------	-----	-------------	-----

Tolerance for dimensions

Warranty period 2 years