



## SQUARES 111x2 230V recessed

### SQUARES 111x2 230V wpuszczany

Category: recessed

Power 2x 50W (2x LED 15W)

Light source: ES111, 230V

Lampholder: GU10

Dimming: Phase-Control

Light source not included

Transformer not required.

#### AVAILABLE FINISHES:

MATT MIX GLOSS CHROME W&B B&W



SQUARES 111x2 230V Phase-Control recessed

35112-0000-U8-PH-xx

-xx finish option code from table below

#### AVAILABLE FINISHES:

##### MATT

alu matt	-01	black matt	-02
white matt	-03	anthracite structure	-18
gold structure	-19		

##### MIX

mix	-06		
-----	-----	--	--

##### GLOSS

black gloss	-22	white gloss	-23
-------------	-----	-------------	-----

##### CHROME

chrom black	-32	chrom white	-33
-------------	-----	-------------	-----

##### B&W

bw black-white	-62		
----------------	-----	--	--

##### W&B

bw white-black	-63		
----------------	-----	--	--

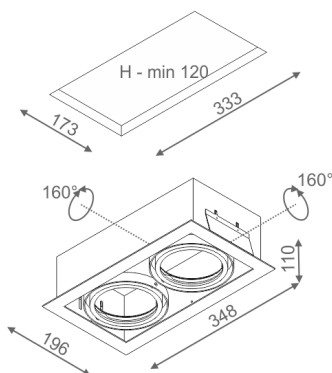

Tolerance for dimensions

Warranty period 2 years