

mechanical connection
„L” connection

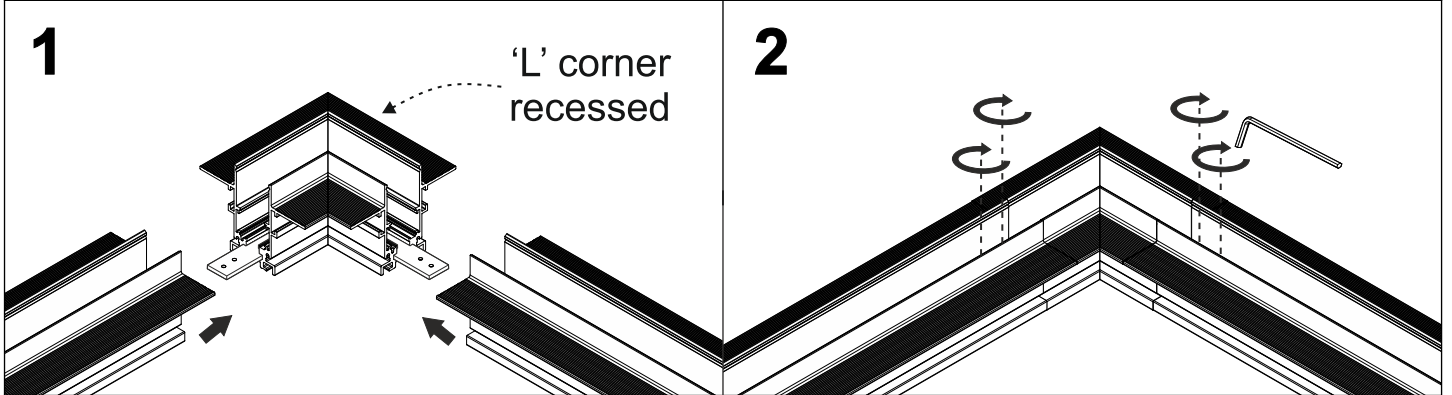

straight connection

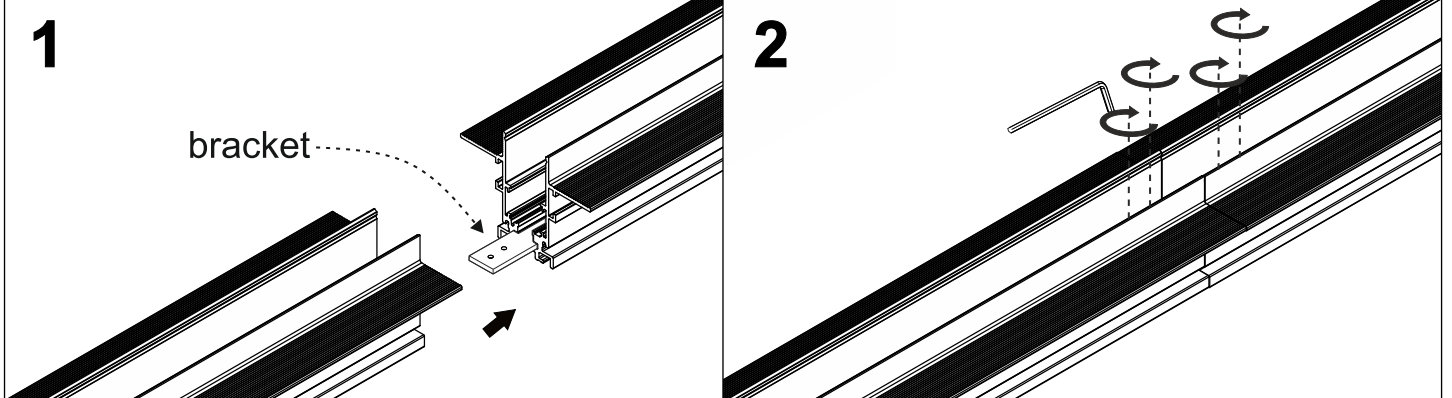

electrical connection

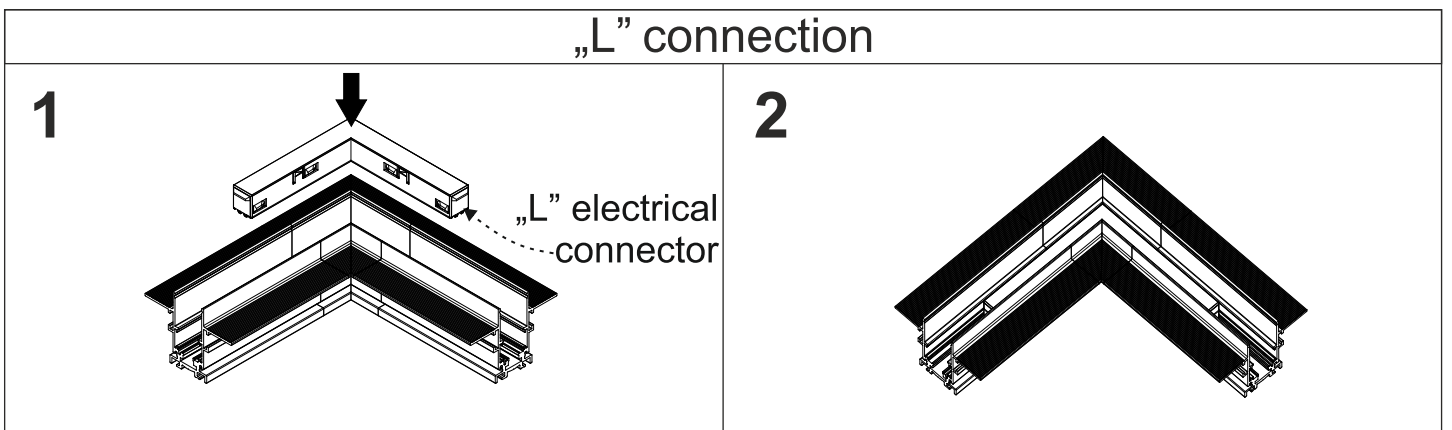

straight connection

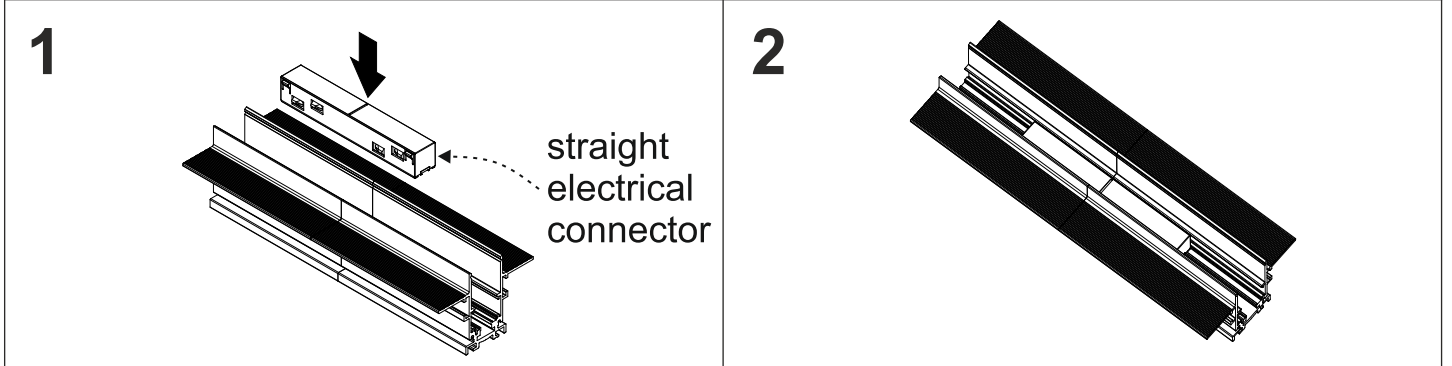

electrical connection

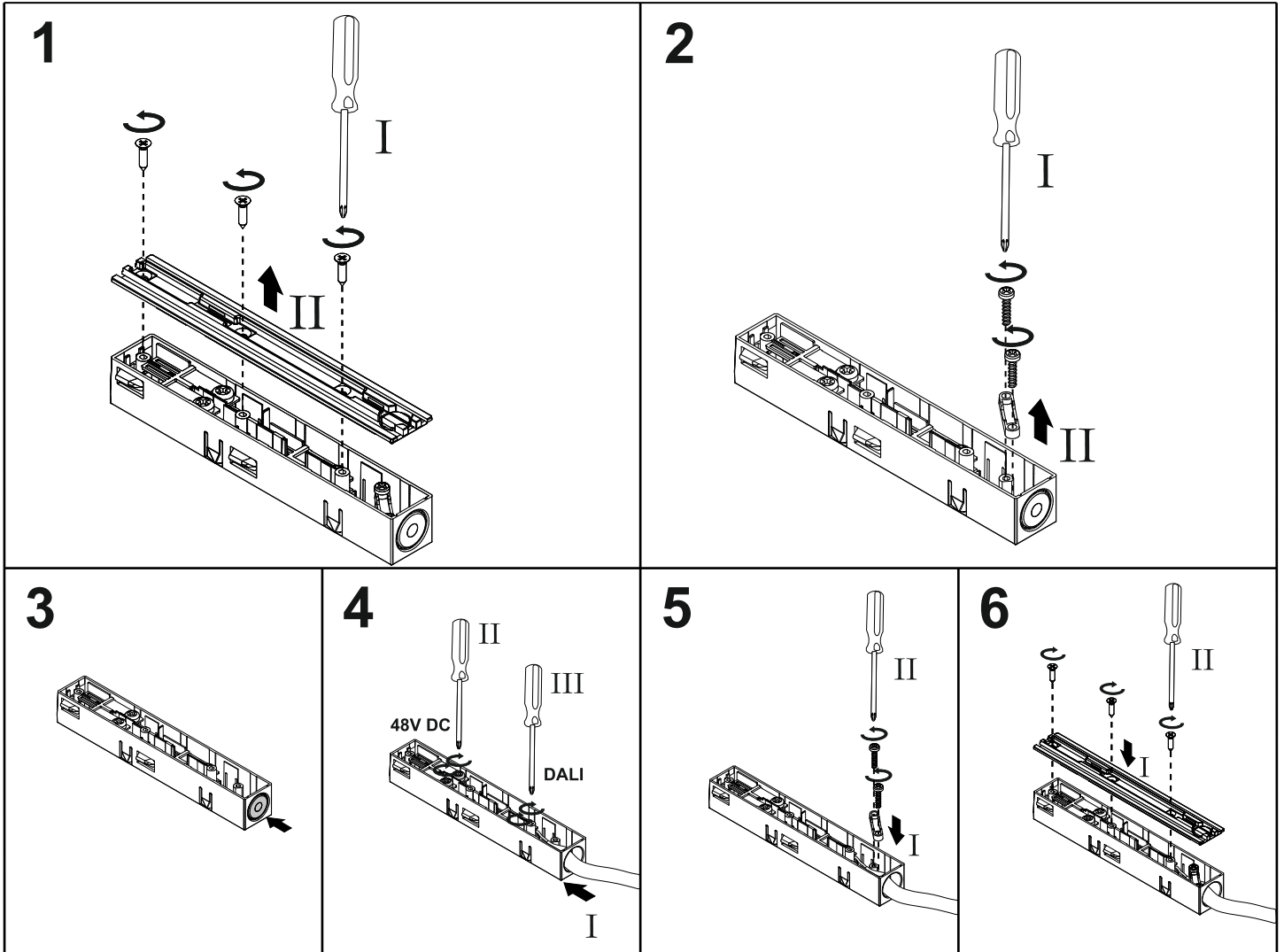

MULTITRACK high recessed - dimensions

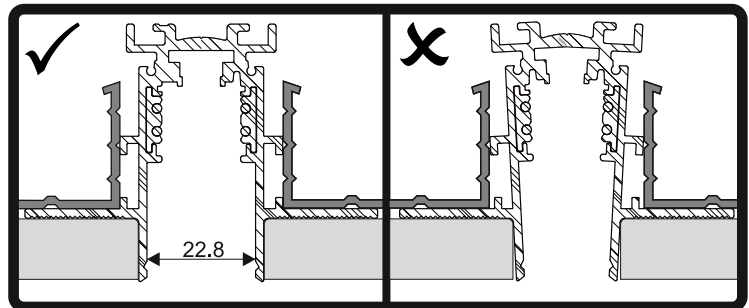
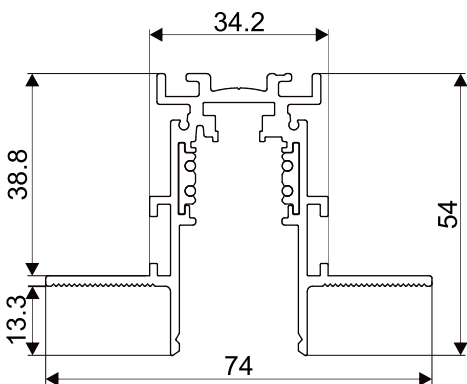

on / off (+ optional DALI)

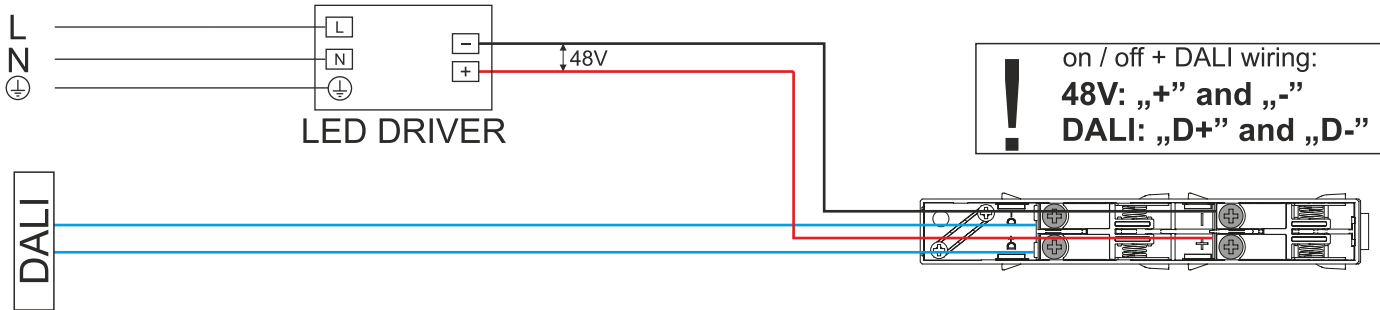

Double circuit on / off

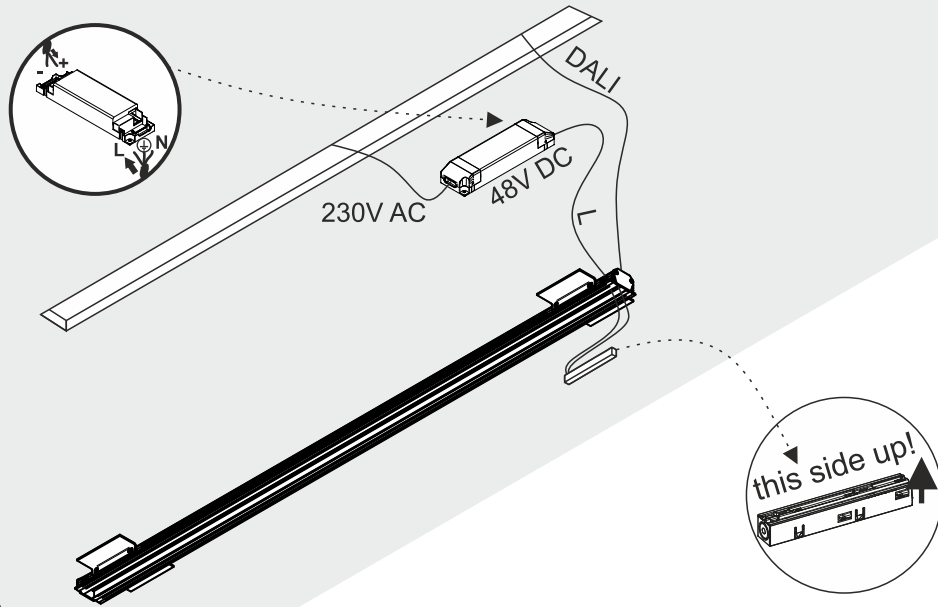
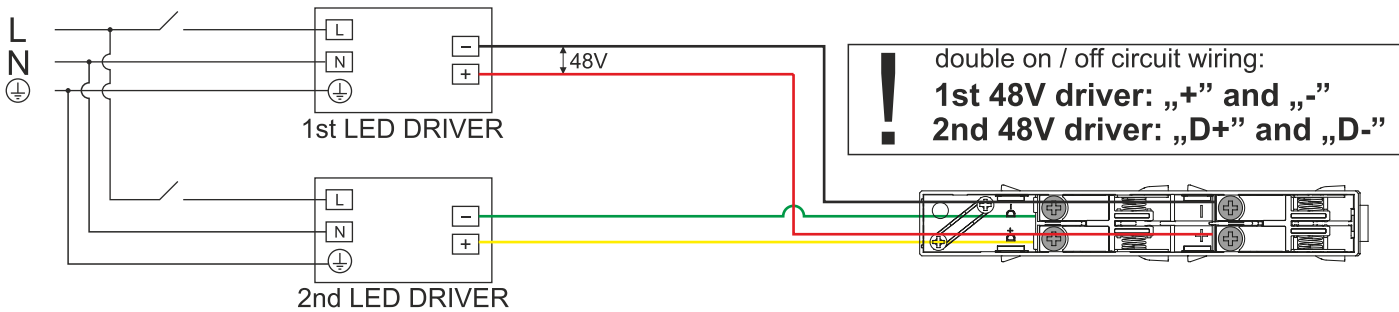

DALI example

(for double on/off circuit connection
replace DALI by 2nd 48V power line)

CV LED driver 48 V - max 150W					CV LED driver 48 V - max 70W				
distance (L)	5m	10m	20m	30m	distance (L)	5m	10m	20m	30m
cable diameter	1,5mm ² / AWG15	2,5mm ² / AWG13	4mm ² / AWG11	4mm ² / AWG11	cable diameter	0,75mm ² / AWG18	1mm ² / AWG17	1,5mm ² / AWG15	2,5mm ² / AWG13

