

connectors	 <p>Connection unit power supply access possible ☉ type A or B (see below pic. a)</p>	 <p>Straight connector unit power supply access possible ☉</p>	 <p>Middle connection unit</p>	
	 <p>L-corner universal power supply access possible ☉ adjustable direction: see below pic. b</p>	 <p>T connector power supply access possible ☉ type: A, B, C, D (see below pic. c)</p>		
	 <p>Adjustable corner adjustable connector: 0-120°</p>	 <p>X connector power supply access possible ☉</p>		

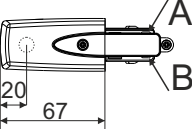

REQUIRED

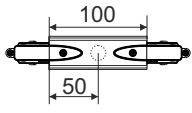

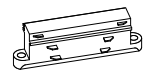
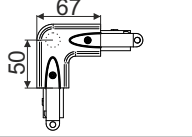
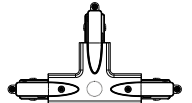
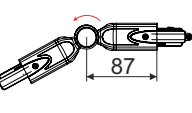
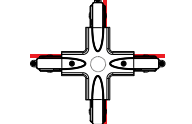
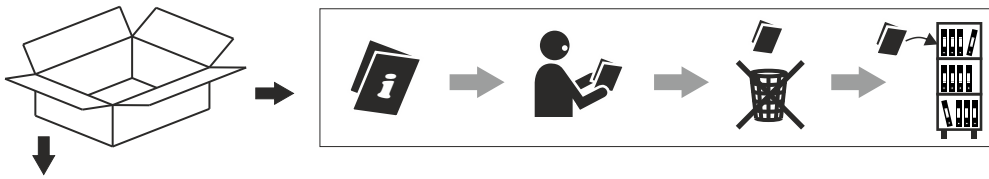
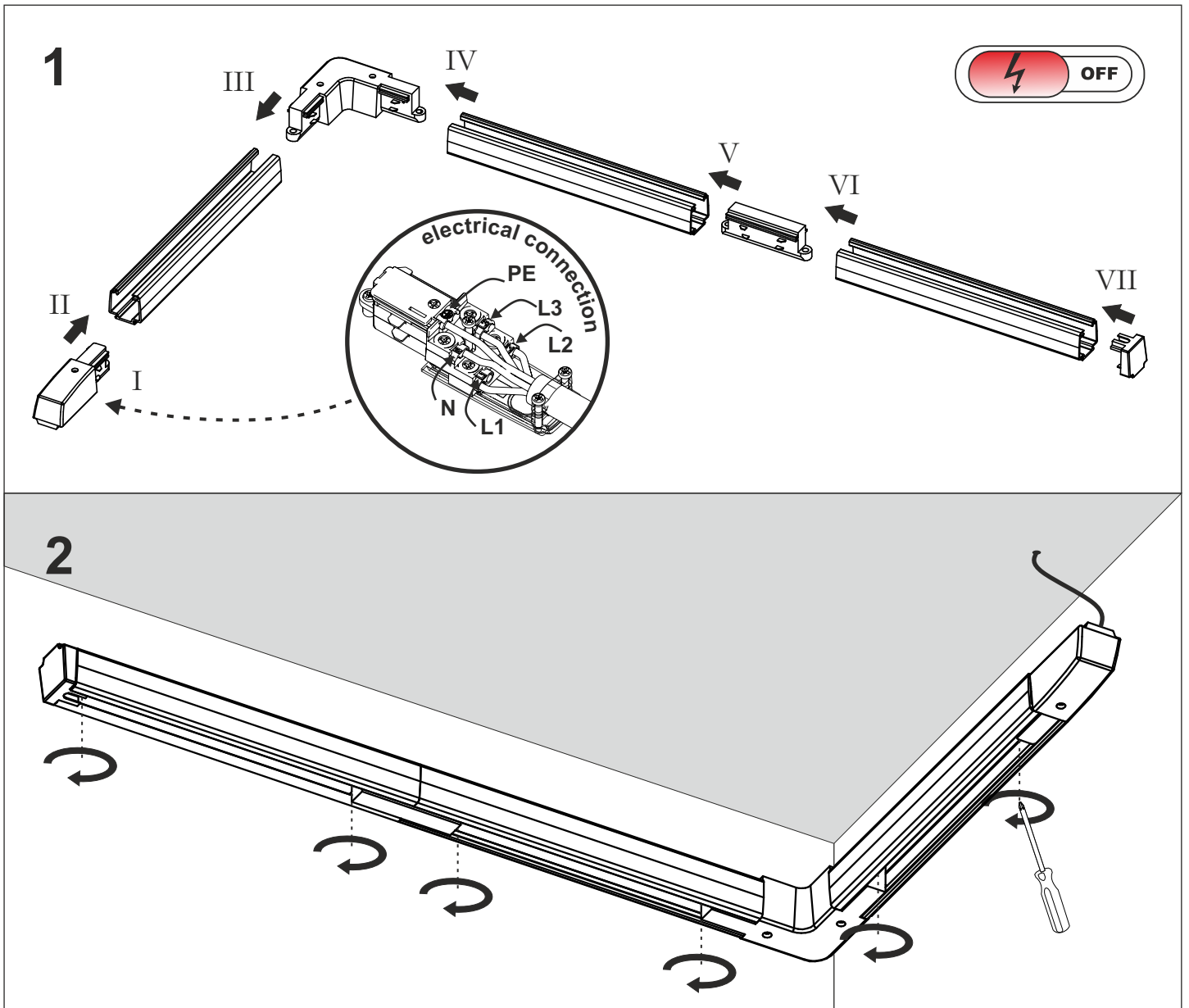
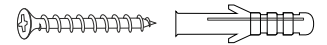
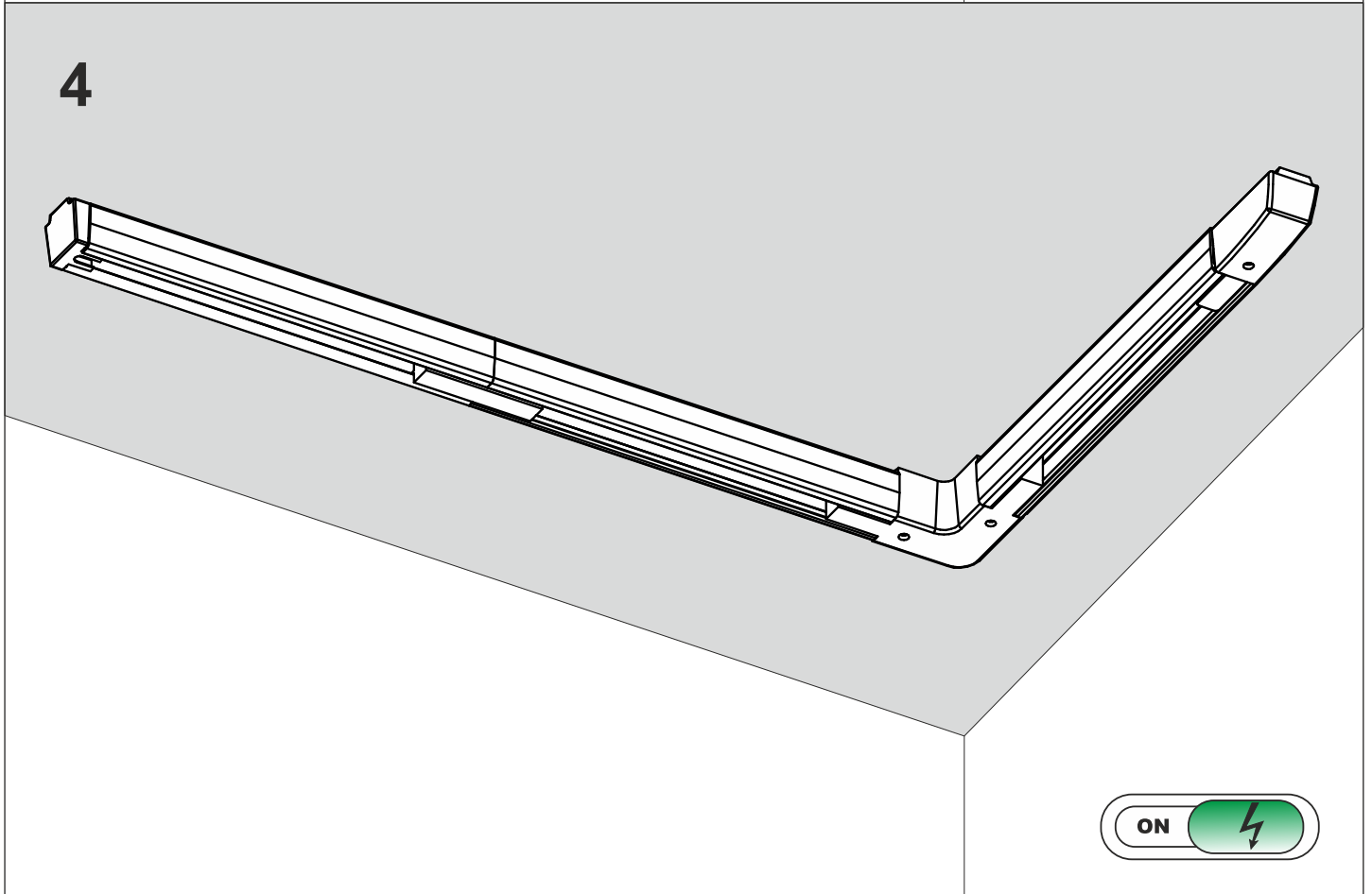
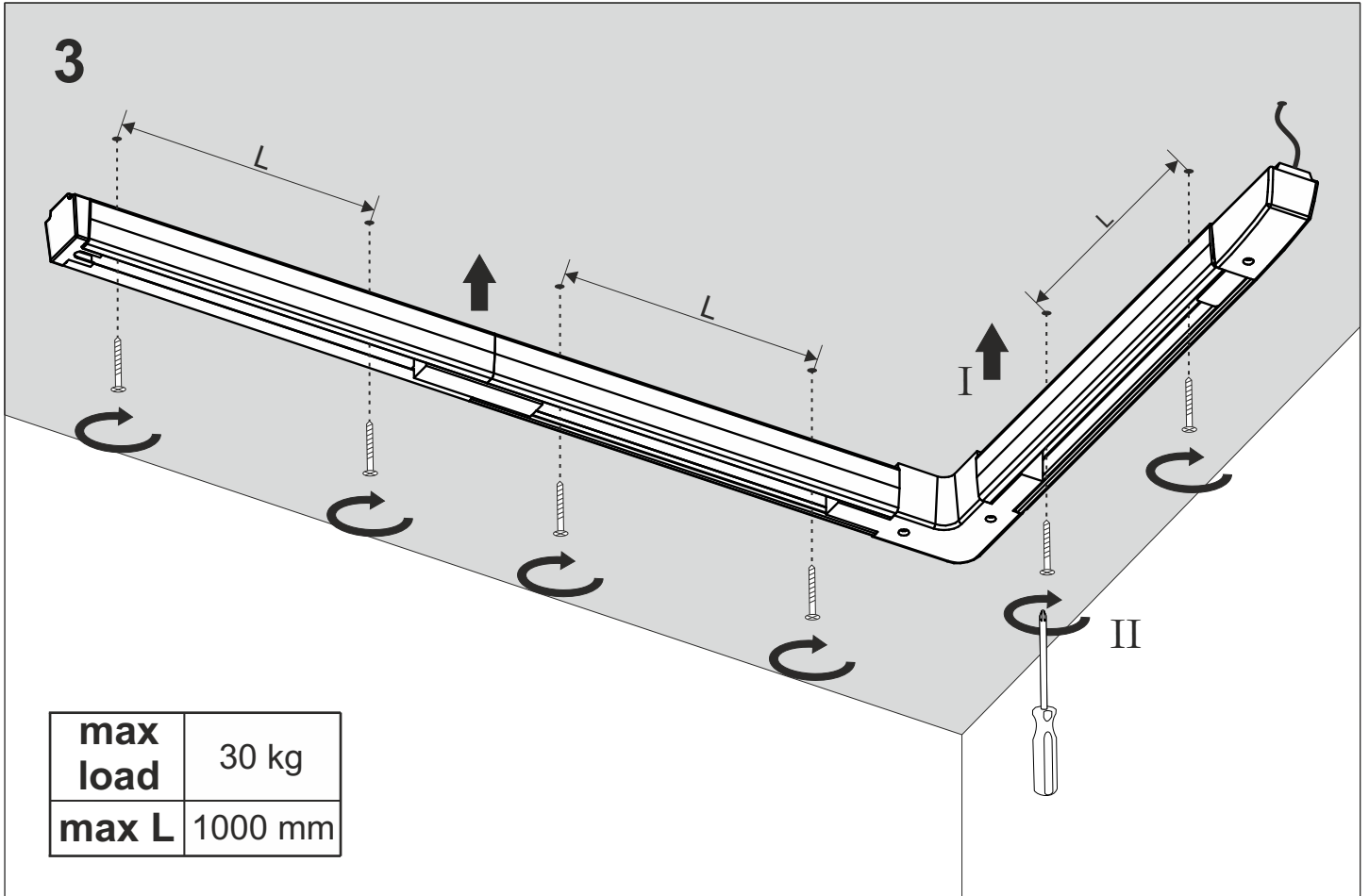

on/off connection

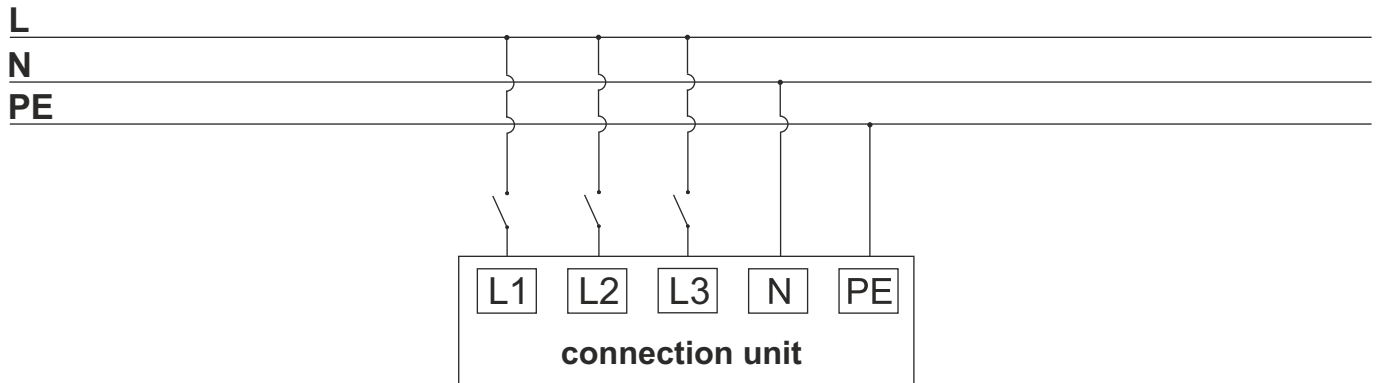

phase-control connection

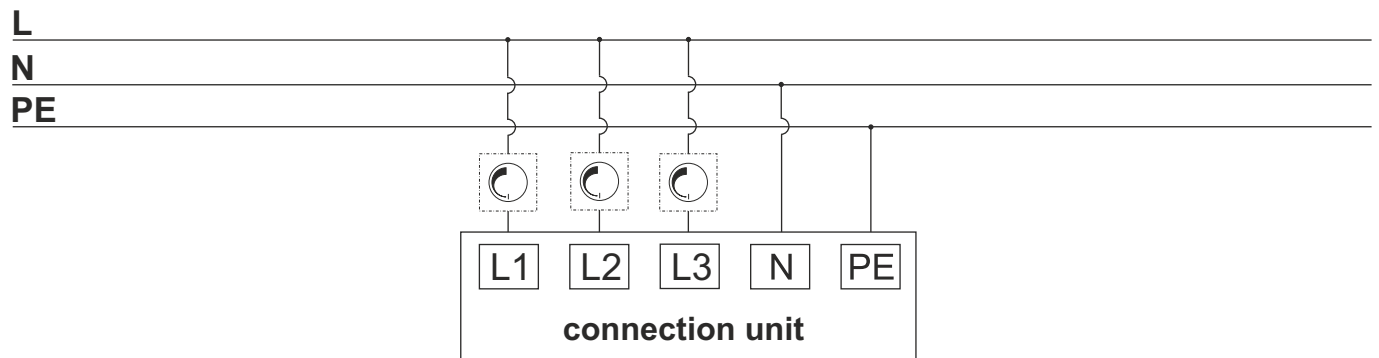

switchDIM connection

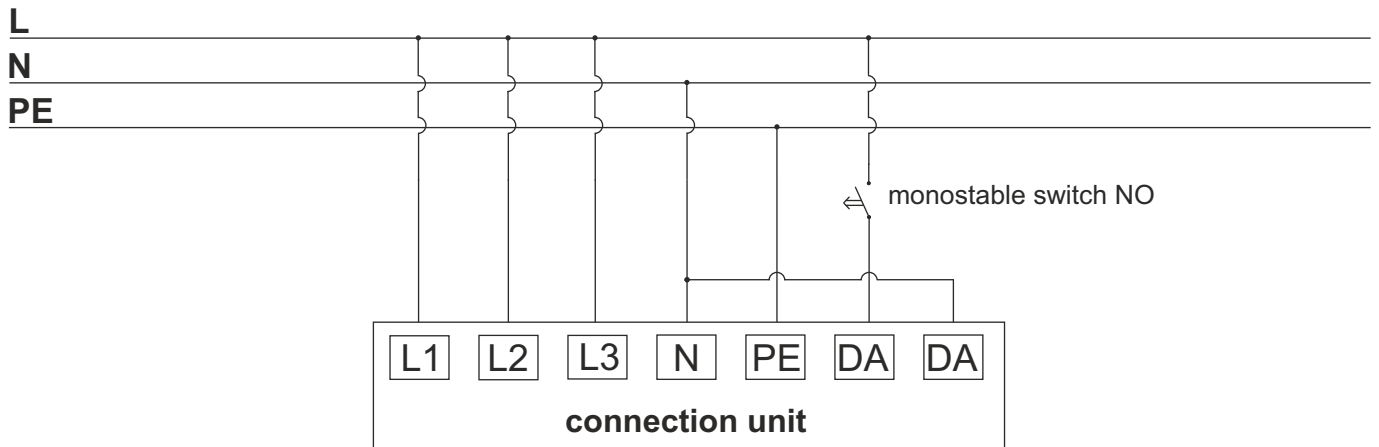

DALI connection

